

Development of MEMS based Pressure Sensor for Underwater Applications

Aarthi E¹, Pon Janani S*¹, Vaidevi S¹, Chandra Devi K¹, Meenakshi Sundaram N¹

¹ PSG College of Technology, Coimbatore, Tamil Nadu, India, *sponjanani@gmail.com

Abstract

Blind cave fish are capable of sensing flows and movements of nearby objects even in dark and murky water conditions with the help of arrays of pressure-gradient sensors present on their bodies called lateral-lines. To emulate this functionality of lateral-lines for autonomous underwater vehicles, an array of polymer MEMS pressure sensors have been developed that can transduce underwater pressure variations generated by moving objects. The underwater object detection capability of the array is demonstrated. The array is capable of determining the velocity and distinguishing various distances of an underwater stimulus with high accuracy and repeatability. The design and simulation was performed using COMSOL Multiphysics 4.3b.

Keywords: lateral lines, blind cave fish

1. Introduction

Aquatic vehicles like sub-marines are used for underwater surveillance. An array of pressure sensor mounted onto these vehicles enables the detection, identification and tracking of obstacles or objects in their path and also provides information about the surrounding flows which could help in reducing the vehicle's hydrodynamic drag.

1.1. Conventional Methods of Sensing

The sonar and optical methods of sensing perform active sensing and in order to work, it will emit light or

acoustic waves and are not energy efficient. The intense sound generated by sonar has shown intense death of marine organisms and also suffers from poor resolution and it reveals the source of generation due to active sensing. Optical methods suffer from poor resolution in case of clouded and dirty water [1]. Aquatic underwater vehicles have limited energy supply and are often operated in cluttered and turbid environments, necessitating the development of passive pressure sensor for under water object detection.

1.2. Motivation

Blind Mexican cave fish has the ability to move at high speed without colliding to other objects and sense the flow of water in a similar cluttered environment using an array of neuromasts called as lateral lines. They are present on and beneath the skin and run down and around their head. The lateral-line consists of two sensory sub-modalities: a system of velocity sensitive superficial neuromasts that responds to flow variations and a canal neuromast system located under the skin that responds to pressure variations. The superficial neuromasts are present on the surface of the skin, while the canal neuromasts are submerged in fluid-filled canals and communicate with the surrounding water through a series of pores. The pressure detection is based on the relative pressure variation between the successive pores and the surrounding flow variation

could trigger an electric impulse to the fish's brain [2]. Unlike the optical and sonar sensing, the fish performs passive sensing i.e it does not spend energy, it just detects the flows around the vehicle and saves energy by not fighting against those flows. It also does not emit optical, electrical or ultra sonic waves that reveal the source or interfere with other forms of life [3].

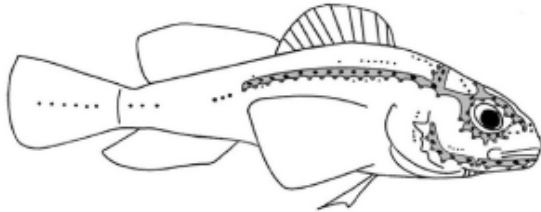

Figure 1: Canal neuromasts represented by dots within shaded region on the fish^[1]

1.3. Flexible Sensing Layer

For sensing applications the material which is preferred most is silicon but it is not well suited for underwater sensing application due to its brittleness and get easily fractured during high flow when it is mounted on the sides of the aquatic vehicle. The vehicle is of curved structure so the silicon due to its stiffness cannot able to fit into it properly. As silicon is having very low value of corrosion resistance, it will react with sea water which leads to rust formation. Due to this disadvantages there will be a limitation in resolution. To overcome these disadvantages elastomeric material is preferred over others. Elastomeric materials have better flexibility and it is chemically inert. For proper mounting of pressure sensor on the hull of the aquatic vehicle, the sensor thickness should be minimized externally without affecting the hull of the aquatic vehicle.

Liquid crystal polymer (LCP) is used as a sensing membrane due to its flexibility. When the stress or strain gets applied to the membrane, it will deform and return back to the original position when the stress or

strain gets removed. LCP membrane is a thermally stable thermoplastic material with a low dielectric constant of 2.9 at 10 GHz with negligible moisture effects. It has lower moisture absorption coefficient (0.02%) and permeability, and higher fracture strength than silicon. LCP has better corrosion resistance so it is free from chemical attacks compare to that of silicon. It has better biocompatibility so it is considered as a suitable material for sensing even in harsh environments [4].

High sensitivity with LCP membrane can be achieved due to its low young's modulus value than silicon. For to preserve sensitivity of silicon, it needs thickness in the range of 2-10 μ m but in case of LCP high sensitivity can be achieved even with 25 μ m thickness. since it has high fracture strength and the thickness range is so high, LCP can withstand high pressure than silicon.

LCP can easily bind to the material than silicon. The membrane should be fixed properly in such a way that the strain act on the membrane should not exceed the maximum strain induced by the diaphragm. Mainly the LCP is preferred over the silicon material due its very good mechanical strength, toughness, excellent dimensional stability, fast cycling, excellent organic solvent resistance and it is considered as the best waterproof material. [5]

Elastomers are rubbery materials and are long chain polymer. The individual chains are amorously tangled with each other [5]. When a stress acts on the elastomer, reconfiguration of polymer chain occurs in order to distribute the stress. When the stress is removed, it will come to its original position and this reversibility cannot be achieved by the use of silicon. But the reversibility is not good when the chains change their conformation during excitation and it will result in stress relaxation. Polydimethylsiloxane (PDMS) is an

elastomer and its potential gets increased due to its flexibility, mechanical properties, inertness and better corrosion resistance, that best suit this application. [6]

2. Use of COMSOL Multiphysics

The simulation of the proposed MEMS based pressure sensor (figure 2) for detecting the objects in underwater was designed using Laminar flow module in COMSOL Multiphysics 4.3b.

2.1. Structural Design

A flexible pressure sensor array is designed in such a way that it mimics the blind cave fish. The array contains ten sensors which are arranged in a row similar to that of fish and also with some spacing so that the crosstalk could be avoided. The individual sensor in the array is composed of a flexible sensing diaphragm which is mounted over a base. The base is attached to the marine vehicle. A standing structure is made to mimic the superficial neuromast of the fish. The strain gauges are placed over the sensing diaphragm to transduce the pressure change into resistance in a metal piezoresistors. [7]

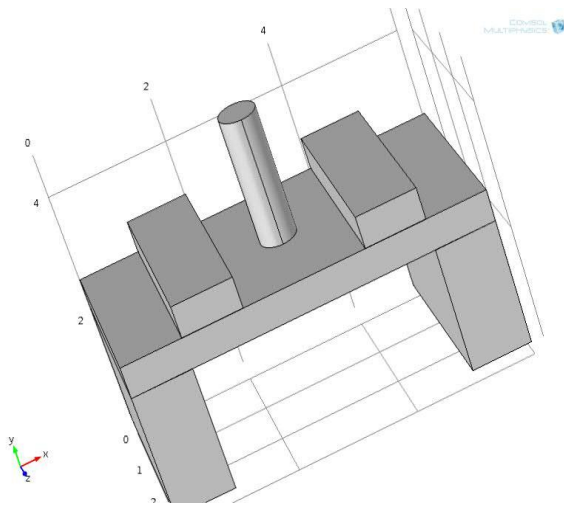

Figure 2: Schematic view of the pressure sensor

2.2. Materials

The sensing layer is made of LCP, that it is flexible, inert, has low moisture absorption co-efficient and could withstand large amount of pressure due to its higher fracture strength. The strain gauge is made of gold piezoresistors since they are inert and has low young's modulus which makes it highly sensitive in combination with the LCP membrane. The standing structure that mimics the neuromast of fish is made of PDMS owing to its inertness and flexibility.

2.3. Physics Applied

The physics used is the laminar flow module in COMSOL Multiphysics 4.3b. The force is applied over the sensing membrane as a boundary stress. The displacement of the diaphragm occurs and the pressure distribution is observed.

3. Numerical Analysis

The sensitivity of the sensor is defined as the change in resistance of the strain gauge for unit stress generated.

$$\frac{\Delta R}{R} = K/E \quad (1)$$

where, σ stands for the stress.

The sensitivity of the device is mainly influenced by the membrane dimensions and strain gauge. The deflection at the sensing layer under uniform pressure could be approximated by

$$w(r) = P_{\text{flow}} a^4 / 64 D [1 - (r/a)^2]^2 \quad (2)$$

where, P_{flow} is the pressure generated by flow variations on the diaphragm, a is the radius of the diaphragm, r is the position along the radial direction ($0 < r < a$) and D is the flexural rigidity of the membrane, given by

$$D = Et^3 / 12 (1 - \nu^2)$$

where E is the Young's modulus and ν is the Poisson's ratio. The equations (1) and (2) helps in determining the

suitable dimensions of the membrane and gauge used in the device [4]. Due to the flow, a pressure difference is set between the atmosphere and membrane. This change results in bending of the diaphragm membrane. The change in resistance value in the piezo-resistors can be read out as voltage. The relative change in resistance depends on the pressure as follows:

$$\Delta R / R = (7.22 * 10^{-27}) P$$

Where, P is the pressure difference across the diaphragm, ΔR is the change in resistance and R is the resistance.[4]

4. Simulation and Analysis

The design was simulated with the help of COMSOL Multiphysics 4.3b and analyzed for parameters such as velocity and pressure distribution for various levels of force exerted over the sensor by the water due to any objects passing.

4.1. Displacement of Diaphragm

The water flow across the sensing membrane sets a pressure difference between the membrane and the atmosphere, resulting in the bending of diaphragm as shown in figure 3.

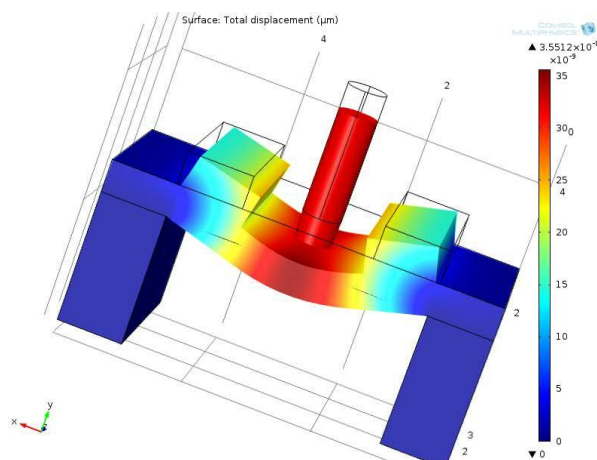

Figure 3: Displacement of diaphragm due to the pressure applied

The elastomer is composed of monomeric units that are tangled with each other. As it gets strained due to the pressure applied, these tangled chains reconfigure themselves to distribute the applied stress which contribute to the bending of diaphragm. The displacement of the membrane shows the pressure experienced by it.

The stress distribution over the diaphragm due to the pressure applied is shown in figure 4.

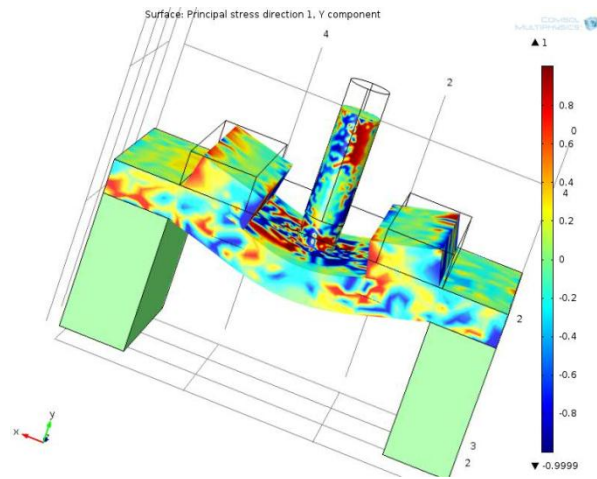

Figure 4: Stress experienced on the sensor due to the applied pressure

4.2. Effect on Velocity

The velocity experienced by the sensor changes with the change in boundary stress exerted over the sensor with respect to the object approaching the underwater vehicle.

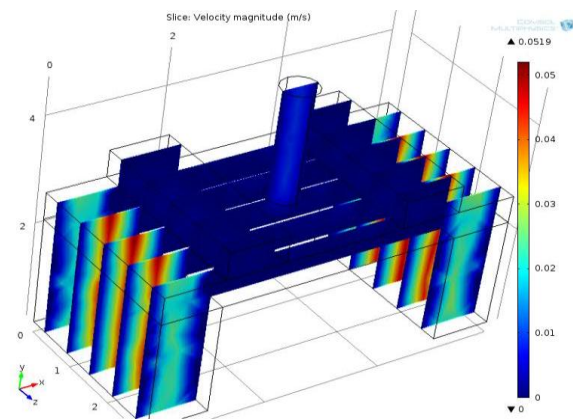
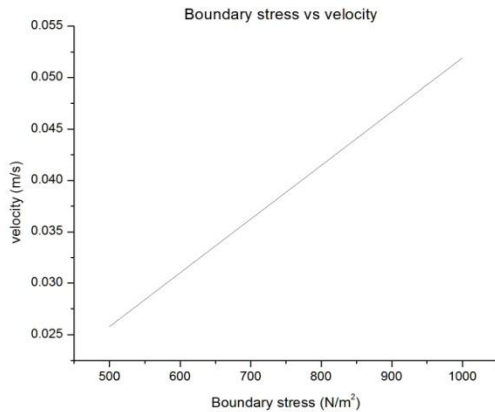

Figure 5: Velocity distribution over the sensor

The velocity experienced by the sensor when a minimum of 5 N/m² and maximum of 1000 N/m² stress applied are 3.672*10⁻⁴ m/s and 0.0519 m/s respectively (Table 1). The velocity of the water increases with the increase in stress created by the object (graph 1).



Graph 1: Variation of velocity with boundary stress

4.3. Effect on Pressure

The pressure experienced by the sensor increases with the increase in boundary stress exerted over the device. The pressure distribution is maximum over the sensing layer determining its sensitivity (Figure 6)

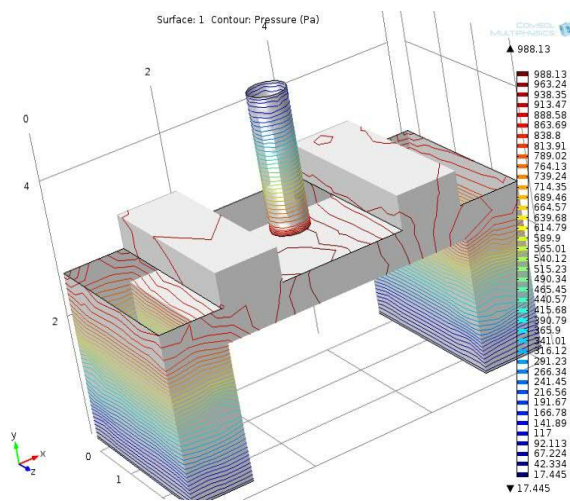
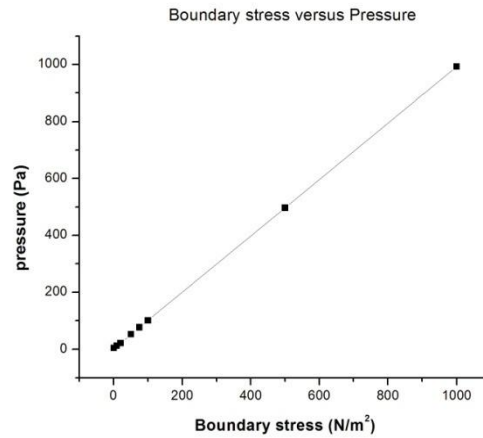

Figure 6: Pressure distribution over the sensor

The pressure change with respect to the minimum of 5 N/m² and maximum of 1000 N/m² stress applied are 4.9126 Pa and 992.48 Pa respectively, as shown in graph 2.



Graph 2: Variation of Pressure with boundary stress

5. Result and discussion

The analysis of the pressure sensor showed increase in resistance with the change in pressure. The change in resistance is measured in terms of voltage across the metal strain gauge (graph 3). The relative resistivity for a minimum of 5 N/m² and maximum of 1000 N/m² stress applied are 3.546*10⁻⁶ and 7.165*10⁻⁴ respectively (Table 1).

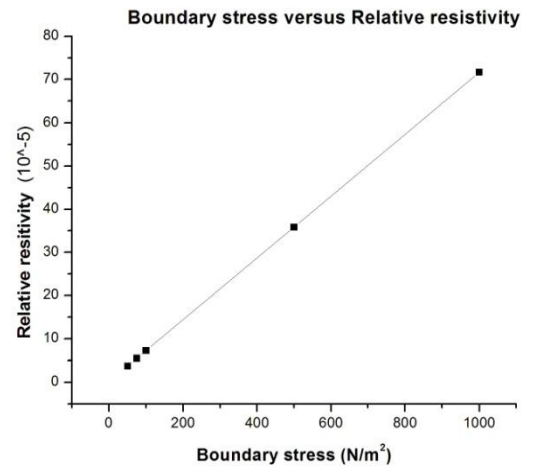

Graph 3: Variation of relative resistance with stress

Table 1: Change in velocity and relative resistance with stress

Boundary stress (N/m ²)	Velocity (m/s)	Relative Resistivity
1	3.672*10 ⁻⁴	3.546*10 ⁻⁶
10	4.760*10 ⁻⁴	9.223*10 ⁻⁶
20	5.890*10 ⁻⁴	1.628*10 ⁻⁵
50	8.340*10 ⁻⁴	3.745*10 ⁻⁵
75	2.360*10 ⁻³	5.509*10 ⁻⁵
100	4.954*10 ⁻³	7.273*10 ⁻⁵
500	0.0258	3.586*10 ⁻⁴
1000	0.0519	7.165*10 ⁻⁴

6. Conclusion

Among the various conventional techniques used for sensing the pressure exerted between the objects and vehicle in underwater, flexible MEMS based pressure sensor is found to be sensitive and safer, as it could detect even a small pressure change of 5 N/m² and does not reveal the point of source. It is also energy conservative since it is a passive sensor. The LCP and the PDMS used could withstand the harsh environment of the sea. It is not hindered by the cluttering and turbidity of sea. It is also cost effective and mechanically stable over a long period of time.

7. References

- [1] Schrope M, Whale deaths caused by US navys sonar, *Nature* **415**, 106 (2002)
- [2] Montgomery M H, Coombs S, Baker F, The mechanosensory lateral line system of the hypogean form of *Astyanax fasciatus*, *Environ. Biol. Fishes*, **62**(1-3):87-96 (2001).

[3] Yang Y, Distant touch hydrodynamic imaging with an artificial lateral line, *Proc. Nat. Acad. Sci.*, **103**(50):18891-18895(2006).

[4] Kottapalli, M. Asadnia, J.M. Miao,G. Barbastathis, A. Flexible Liquid Crystal Polymer Mems Pressure Sensor Array for Fish-like Underwater Sensing. *Smart Materials and Structures*, **Vol. 21** 11(2012).

[5] Someya T. A large-area, flexible pressure sensor matrix with organic field-effect transistors for artificial skin applications. *Proc. Nat'l Acad. Sci.*,**101**(27):9966-9970(2004).

[6] Wang, Ding T, and Wang P. Thin exible pressure sensor array based on carbon black/silicone rubber nanocomposite. *IEEE Sensors*, **9**(9):1130-1136(2009).

[7] Yang Y, Chen J, Tucker C, Pandya J, Jones D, Liu C. Biomimetic flow sensing using artificial lateral lines. *ASME Conf. Proc*, 43025:1331-1338(2007).